

HardiePanel[®]

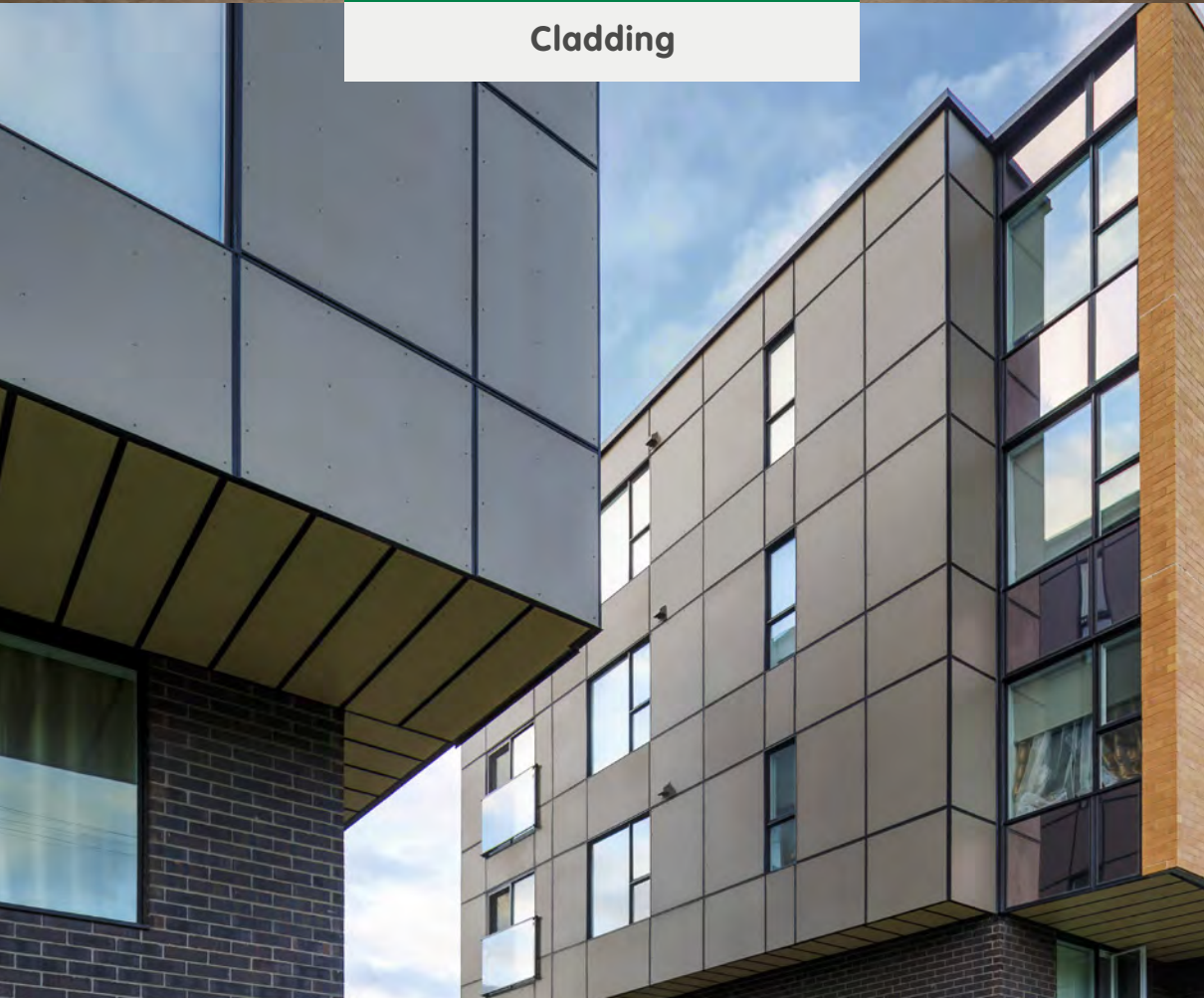

Cladding



Installation Guide



Contents

General	5
Handling & Storage	9
Tools & Accessories	10
Cutting	12
Painting	15
Preparation	16
Installing HardiePanel® Cladding with the Nvelope System	21
Installing HardiePanel® Cladding onto Timber Battens or Masonry	37
Maintenance	48
Health & Safety	49
General Information	51



General

HardiePanel® cladding is an 8 mm thick large format panel for residential and commercial schemes. The product is installed as part of a ventilated rainscreen facade system fixed to timber frame, steel frame or masonry walls using corrosion resistant screws, nails or rivets. HardiePanel cladding can be installed on facades or soffits, with or without insulation.

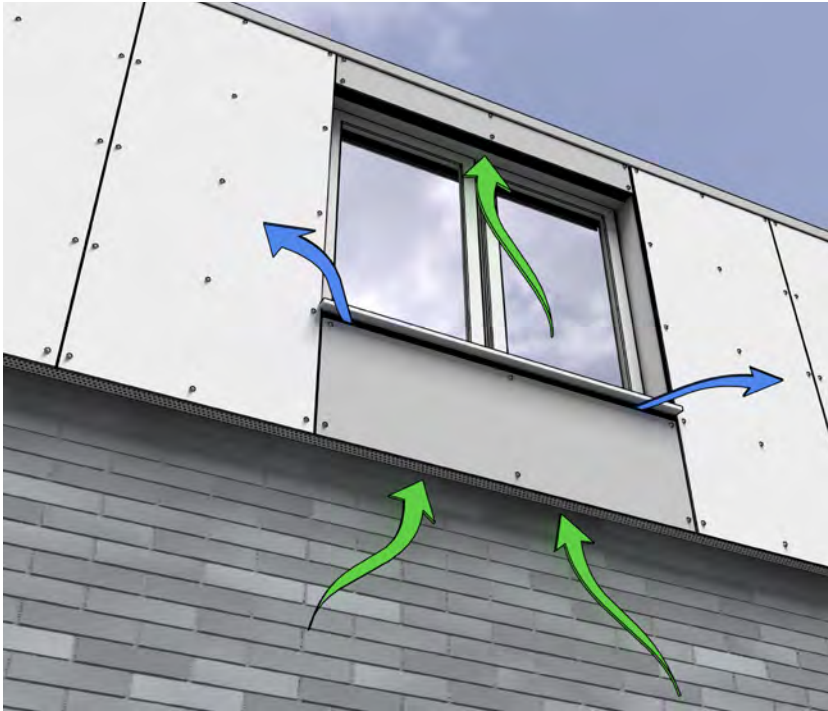

Ventilated facade system



Note: Cladding with HardiePanel boards must always be carried out as a ventilated facade with minimum 20 mm distance between the cladding and the rear lining (insulation material). However, in special situations (e.g. high rise buildings) local regulations may demand a larger ventilation gap. Inlet and outlet openings must have a cross section of at least 100 cm²/m.

Composition

HardiePanel® cladding is made of Portland cement, milled sand, cellulose fibres, water and selected additives.

Characteristics

Dimensions:

The panels are supplied square and straight according to EN12467 – level I.

HardiePanel cladding sizes

Length	Width	Thickness	Weight	Density
3050 mm	1220 mm	8 mm	11 kg/m ²	1300 kg/m ³

Textures

HardiePanel cladding is available in two textures:

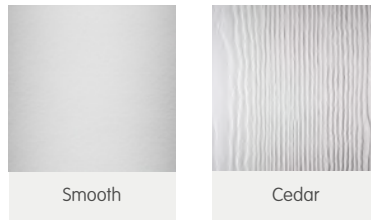

Finishes

HardiePanel cladding is available in two finishes:

- ColourPlus™ Technology: provides a quality system for multi-coat, factory-applied coating and curing. Available in 21 different colours.
- With PrimePlus® Technology: custom painted to order or site painted in the correct conditions within 90 days of installation.

Quality & Certification

The production of HardiePanel® cladding is audited annually by external auditors. HardiePanel cladding product specifications and classifications comply with EN 12467:2012 and 13501-1. HardiePanel cladding is BBA certified.

Protective Film

HardiePanel cladding with ColourPlus™ Technology is equipped with a PE film for protection of the surface during transportation and processing. PE is an environmentally friendly polymer, which can be recycled.

Sub-Frame

HardiePanel cladding can be installed on timber, aluminium or steel sub-frames.





Handling & Storage

Store flat and keep dry prior to installation. In storage a maximum of 4 pallets can be put on top of each other. Keep away from weather influences. Products stored outside should be covered with a waterproof covering in addition to the product wrapper to avoid contact with water and dust. Wet products cannot be installed. Installing wet cladding will result in shrinkage at butt joints. The waterproof sheet should not cover the pallet timber to ensure adequate ventilation. James Hardie is not responsible for damage caused by improper storage and handling of the product.



Carry panels on edge

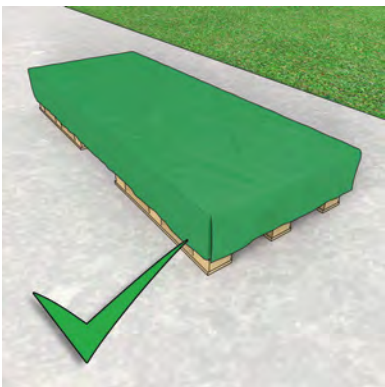

Protect from rain

Tools & Accessories

Supplied by James Hardie:

EPDM Tape



To cover the vertical joints for timber frame only. Lengths of 20 m in 60, 80, 100 and 120 mm widths.

HardiePanel™ Screws*



With (un)coloured head \varnothing 12 mm. A2 austenitic steel. 4.8 x 38 mm. The screws have a sharp point and a fast cutting thread, which ensures a firm fixing with a high pull out value.

Metal corner for HardiePanel® cladding

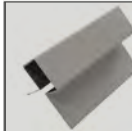

Box section profile for finishing external corners. Length 3 m.

HardiePanel™ Rivets*



Stainless steel mandral facade rivets 4.8 mm x 18 mm x 14 mm diameter head. Available in colours to match our ColourPlus™ Technology palette.

Horizontal Zed Profile (HZP)



To cover all horizontal joints. Lengths of 3 m. Required only for altitudes of 600 m or above.

HardieBlade™ Saw Blade



160 (20/16), 190 (30/20), 254 (30) or 305 (30) mm diamond tipped saw blade to reduce dust production and decrease wear.

Ventilation Profiles



Using ventilation profiles ensures the correct level of inlet and outlet ventilation. Available in 4 sizes to suit 25 mm, 38 mm, 44 mm and 50 mm battens.

HardieSeal™ Edge Coating



To touch-up cut edges and small damages. Available in 1 litre or 500 ml cans.

*All fixings are A2 as standard, A4 fixings are available for marine environments.

Waterproof Membrane

The installation of a breather membrane acting as a vapour permeable water-barrier will be necessary for timber frame buildings or block walls where the wall is not considered waterproof. This barrier must meet the requirements of BS EN 13859:2005.

Wooden Battens

The minimum requirement for wooden battens is 25 mm.

Aluminium & Steel Sub Frames

Proprietary systems readily available. Please see manufacturers' details for specification and installation information.

Centralising Tool

For use with rivet installation.
Use on the pre-drilled panel to ensure a concentric hole is drilled in the aluminium behind the panel.

Rivet Gun

For use with rivet installation for installing rivets. Please note rivets must not be installed with mechanical tongs.

Stand-off Head Attachment

For use with rivet installation.
To enable the rivet fixings to have a rattle fix.

Saw Equipped with HardieBlade™ Saw Blade with HEPA Extraction

Proprietary systems readily available. Please see manufacturers' details for specification and installation information.

Jigsaw

For cut outs. T1 41 Bosch blade or equivalent recommended.

Cutting

Safety

As with all other building materials safety precautions must be taken into account. Cutting and drilling are subject to dust development, and proper precautions must be taken. Dust from fibre cement boards is characterised as mineral dust and EU-approved respirators can be used in conjunction with the following cutting practices to further reduce dust exposures.

Cutting Instructions

Cutting should always be done outdoors

1. Position cutting station so that wind will blow dust away from user and others in working area
2. Use one of the following methods based on the required cutting rate:

Preferred Cutting Method

Dust reducing circular saw equipped with a HardieBlade™ saw blade and HEPA vacuum extraction.

Acceptable Cutting Method

Dust reducing circular saw with a HardieBlade saw blade (only use for low to moderate cutting).

Minimum Cutting Method (for low to moderate cutting only)

Hand saw with hardened teeth.

NEVER use a power saw indoors.

NEVER use a circular saw blade that does not carry the HardieBlade saw blade trademark.

NEVER use a grinder or continuous rim diamond blade for cutting as they produce too much dust.

When cleaning up dust and debris, **NEVER** dry sweep as it may excite silica dust particles into the user's breathing area. Instead, damp debris down with a fine mist to suppress dust during sweeping, or use a HEPA vacuum to collect particles.

ALWAYS follow tool manufacturer's safety recommendations.

Sanding/Rebating/Drilling/Other Machining

If sanding, rebating, drilling, or other machining is necessary, you should always wear a dust respirator in compliance with local requirements (e.g. EN 149, FFP2/3) and warn others in the immediate area.

Important Note: For maximum protection (lowest respirable dust production), James Hardie recommends always using 'Preferred' level cutting methods where feasible. HSE approved respirators can be used in conjunction with above cutting practices to further reduce dust exposures. If concern still exists about exposure levels or you do not comply with the above practices, you should always consult a qualified industrial hygienist or contact James Hardie for further information.

For further information, refer to our Material Safety Data Sheet available at www.jameshardie.co.uk.

Typical details for HardieBlade™ Saw Blade

Diameter	Ø160	Ø190	Ø254	Ø305
Width mm	4 mm Issued with reducing washers	4 mm Issued with reducing washers	4 mm	4 mm
Bore size	20/16 mm	30/20 mm	30 mm	30 mm

Cut-outs: Use a jigsaw or a hole saw equipped with a hard metal, bi-metal or diamond tipped blade. A min 8 mm hole is to be drilled at the inner corner to avoid cracking of the board.

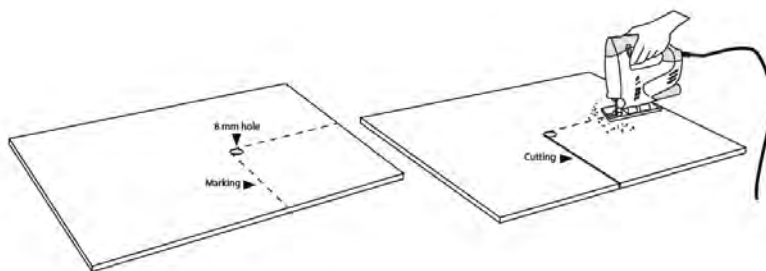

After cutting and only if necessary the edges may be bevelled with a fine sand paper block.



Painting

If cut to size the edges of the HardiePanel® cladding must be sealed with HardieSeal™ edge coating prior to installation. HardieSeal edge coating should be applied with a small paint pad or household sponge.

DO NOT APPLY HARDIESEAL EDGE COATING TO THE FACE OF THE PRODUCT.

HARDIESEAL EDGE COATING SHOULD ONLY BE USED ON THE CUT EDGES.

HardieSeal edge coating may also be used to deal with small scratches and marks less than 6 mm in diameter.

Wipe off any excess from the front face immediately. The paint should be used sparingly and restricted to the area of damage otherwise it may become visible. If the damage is still visible the panel should be replaced.

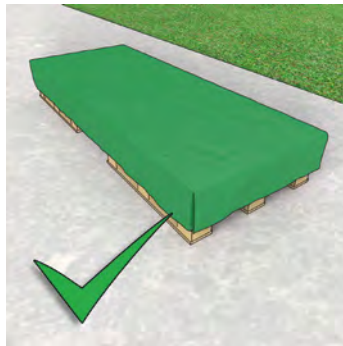

HardiePanel® Cladding with PrimePlus™ Technology

Do not use stain on James Hardie® products.

It is recommended that HardiePanel® cladding with PrimePlus™ Technology be factory coated by a third party establishment. Should this option be unavailable, HardiePanel cladding with PrimePlus Technology must be painted within 90 days of installation. 100% acrylic topcoats are recommended. Ensure compatibility with James Hardie primer before painting. If in doubt, perform an adhesion test. Do not paint when damp or wet as this will result in the paint not bonding to the product. For application rates refer to paint manufacturer's specifications. Spray application is not recommended.

Preparation

Construction

James Hardie does not specify the fastening requirements for the framing to the building and will not take the liability of such structural elements. The attachment of the framing should be incorporated into the overall building design and should be approved by the responsible parties.

Structure

The structural wall to which HardiePanel® cladding is to be fixed, must be of sufficient strength and stiffness to satisfy the requirements of the local building regulations in its own right under the design dead and live loads. The wall may be made of masonry, timber or steel. In the case of the latter, a sheathing board (i.e. HardieWindbreaker™ board) must be installed over the steel frame/ behind the rainscreen facade.

Waterproof Membrane

A waterproof membrane is required if the substrate is not waterproof. Fix a waterproof membrane to the outer face of the structural wall, laid along the wall, with an overlap between the layers of membrane of at least 150 mm. The wall may be made of masonry, timber or steel. In the case of the latter, a sheathing board must be installed over the steel frame/ behind the rainscreen facade.

Preparing the Frame

The sub frame creates a ventilation cavity (minimum 20 mm) between HardiePanel cladding and the substrate. The top and base of the frame must be finished with a ventilation grille. Horizontal framing should be avoided as this can block the ventilation.

Wind load

Frame type	Framing/stud centres (mm)	Fixing type/dimensions (mm)	Fixing centres vertically (mm)	Max wind pressure (kPa)
Aluminium rail fixed to timber, masonry or steel frame	600	5.5 x 25 mm stainless steel screws* Aluminium Body/Stainless Mandrel Facade Rivets 4.8mm x 18mm x 14mm Ø head. Stud and vertical centres are the same as screws: Value is 1.4 kPa	400	1.4
Timber battens fixed to timber frame, masonry walls or timber battens fixed into aluminium rails	400	4.8 x 38 mm stainless steel screws*	300	1.73

*Self-drilling/tapping screw with 12 mm head diameter.

EDPM Gasket Tape for Timber Frames

The EPDM gasket tape is used behind every vertical joint on timber. It provides additional weather protection to the battens to prevent them rotting prematurely.

Install by stapling to the top of the batten, then allow the gasket roll to drop, take out any slack and place staples at regular intervals down its length. Trim to size.

Important note: Do not stretch the EPDM gasket as this could lead to it pulling over the staple fixings.

MetalTrim™ Installation

Important note: MetalTrim™ corner profiles are to be installed vertically only.

Cutting MetalTrim

1. Cut the MetalTrim with a suitable saw or shears.
2. Ensure that the cuts are clean and straight.
3. Ensure that the trim is not damaged during the cutting operation.

Installation

Fix the trim with stainless steel nails. Ensure that you do not overdrive or underdrive nails.

When joining pieces of trim together ensure that the trim is correctly aligned prior to fixing. Pay attention to thermal expansion where exposure of the MetalTrim to sun is extreme. When fixing the trim, fix the trim at the top first, then the base then fix at remaining locations. Maximum spacing of fixings is 1.5m. It is imperative that the plastic protection is removed immediately after installation otherwise it will become trapped behind the cladding and be difficult to remove. Refer to detail page 26.

Screws on Wooden/Metal Sub-Frames

HardiePanel® cladding does not require pre-drilling. Screws should be applied by hand using the correct Torx 20 driver bit. Moderate pressure should be applied to the fixing. The head of the fixing should be driven flush with the surface of the board. Do not over tighten as this may put undue stress on the board.

The fixing should be positioned 50-100 mm down from the horizontal edge of the board. Then, in from the vertical edge by 20 mm, if wooden frame or 30mm, if metal frame. Vertical fixing centres are determined via the wind load table, page 16.

Do not use aluminium screws, staples, clipped head nails or second fix pins to install the HardiePanel boards.

Prior to installation check if the products are fit for purpose and in accordance with specifications laid down in this document. HardiePanel cladding is fixed as per the drawing section.

Rivets on Metal Sub-Frames

HardiePanel® cladding will require pre-drilling. Install the fixed point rivet first. The fixed point hole should be 5 mm. Then use the centralising tool to drill 9 mm holes into the aluminium sub frame. Using the rivet gun (remembering to apply stand off head) install all of the rivet fixings. To be clear, all fixings should be rattle fixed except for the central point.

Clearances

Do not install the panels in such a way that they remain in contact with standing water.

Install HardiePanel cladding in compliance with local building regulations requirements for clearance between the bottom edge of the cladding and the adjacent finished grade. This is typically 150 mm.

Maintain a minimum 50 mm clearance between HardiePanel cladding and paths, steps, driveways and roofing elements.

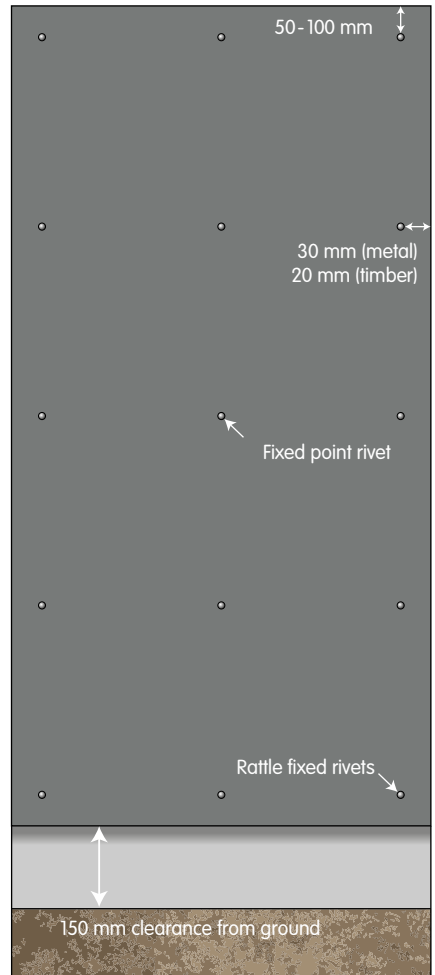

Fixing the First Board

A minimum 10 mm drip edge is required at the lower edge of the first board.

The HardiePanel board can be installed either vertically or horizontally, both can be installed on a vertical sub-structure. The guidelines for fixing positions are identical for either layout. Panels can be fixed with a maximum 8 mm gap between adjoining boards. They can also be butt-jointed. However, due to factory tolerances, this is only recommended when the panels are fully cut to size.

Fixing the Second and Subsequent Boards

The Horizontal Zed Profile (or similar profile) can then be installed over the top edge of the first and subsequent boards to protect the joint. Counter flashing shall be installed as per the manufacturer's instructions.

Wall Penetrations

When a penetration in the wall is required, for a pipe or tap for example, form a hole in the panel using a carbide tipped hole saw. Make the hole approx. 6mm larger than the diameter of the pipe. Seal between the fitting and the edge of the hole with an exterior quality sealant. If the space between the fitting and the hole is too wide, use a polyethylene foam-backing rod to fill the major part of the gap. The remaining gap should be filled with sealant.

Load Bearing

HardiePanel cladding is not intended as a load bearing or shear element in the wall construction. Items required to be attached to the wall should be supported directly by connections to the structural sheathing and/or framing members, not attached to the cladding as the primary load bearing elements.

Lightweight finishing grilles can be bonded to the face of the product using a construction adhesive.



Installing HardiePanel® Cladding with the Nvelope System

General Description Metal Frame

HardiePanel® cladding can be installed onto an aluminium system. The sub frame consists of a bracket and vertical 'T' and 'L' rail (T profiles to be used for panel joints, and L profiles to be used in intermediate positions). The brackets are secured directly to a new or existing substrate of; concrete, brickwork or blockwork, steel, timber frames or SIPS. Stainless steel fixings are recommended to prevent bimetallic corrosion.

Vertical Rails

Once a line of vertical brackets is installed, 'L' rail/'T' rail can be attached using the 'helping hand' at each bracket position. As the panels will follow any irregularity or miss-alignment of rails, it is important that time is taken to align and level the framework to a high standard.

Each 'L' or 'T' profile rail should be cut to the required length from a standard length rail. Place the rail in each of the brackets using the helping hand to support the rail. Allow 10mm expansion gaps between rails. Profiles can then be eased outwards to form the specific cavity depth. Secure the rail using stainless steel screws to the fixed or sliding points.

For the correct combination of single/double brackets, fixed and sliding points you should contact your aluminium system provider.

For more information please see www.nvelope.com

Insulation

When insulation is specified, it should be cut and tight butted around the brackets and secured with appropriate fixings. Sufficient insulation fixings should be provided to ensure that the insulation cannot block the ventilation cavity.

Design & Loading

The design and loading capability of the metal back frame is to be determined by the metal frame provider.

Please consult with your metal frame supplier prior to starting installation so that the correct system can be specified for your project

Fire Stopping

Any opening in the structure should be adequately fire stopped as per the contract performance requirements. Refer to the fire stopping manufacturers guidelines for the application in question.

General Arrangement for NV1

Masonry Nvelope NV1 System General Arrangement

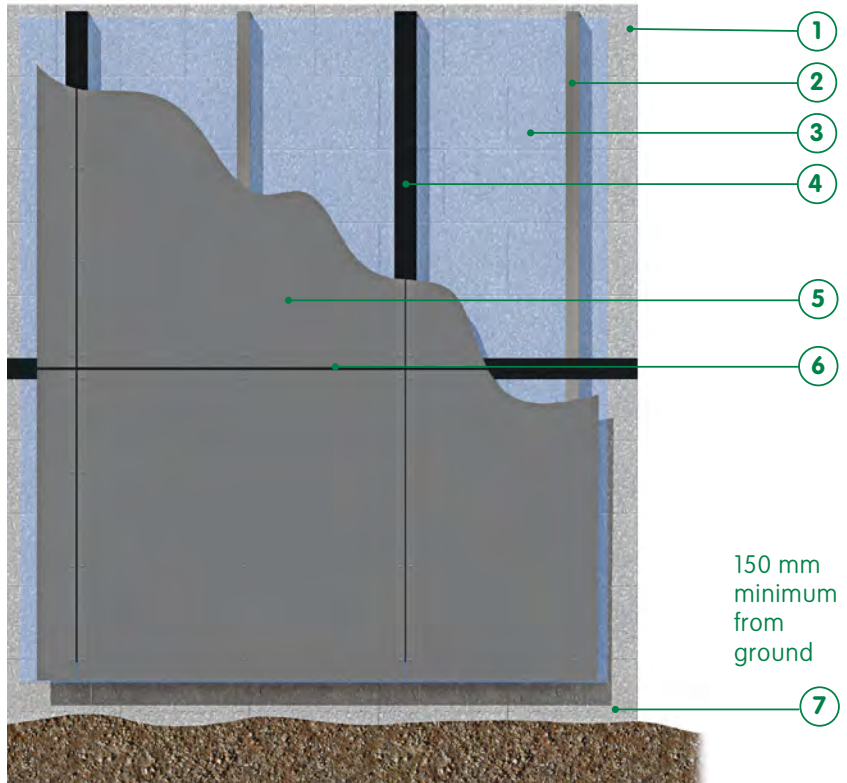

- 1** Masonry or steel frame
- 2** Nvelope bracket system
- 3** Breather membrane (behind insulation if required)
- 4** Black tape
- 5** HardiePanel® cladding
- 6** Z-Profile (if required)
- 7** 150 minimum gap from ground

Fixings installed

(see pages 18-19)
50-100 mm from the top
30 mm in - Metal
20 mm in - Timber

Nvelope NV1 External Corner Trim Profile with Rivet Fixing

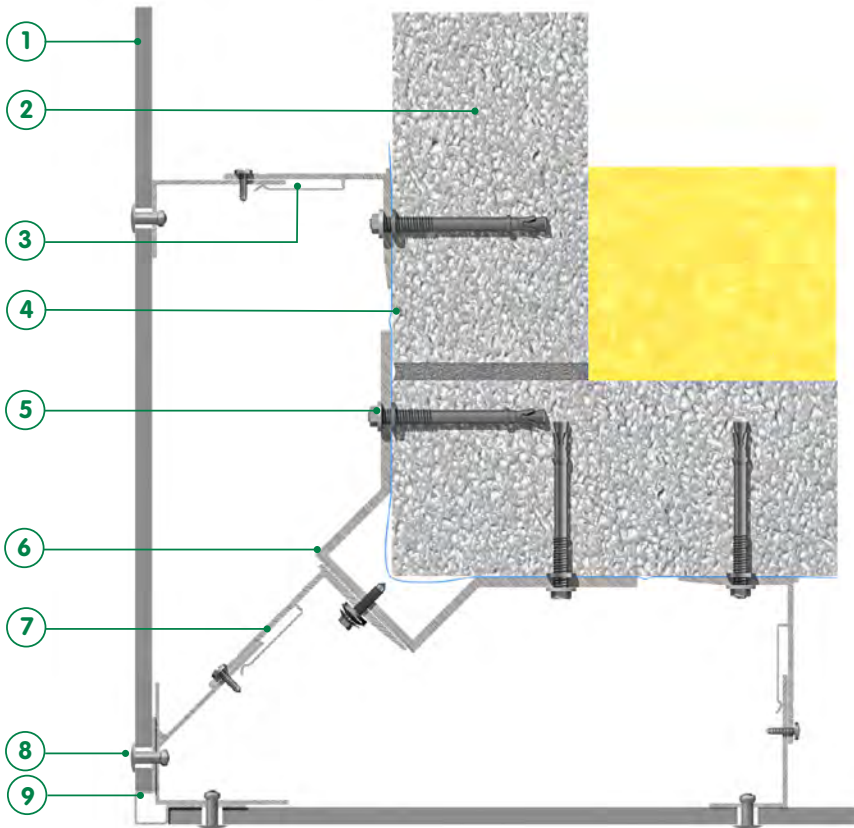

- 1 HardiePanel® cladding
- 2 Masonry
- 3 Nvelope bracket system
- 4 Breather membrane (if required)
- 5 Expanding anchor fixing
- 6 Nvelope corner bracket
- 7 Nvelope bracket and corner profile
- 8 HardiePanel™ rivets for metal frame
- 9 MetalTrim™ external corner profile

Nvelope NV1 Internal Corner with Rivet Fixing

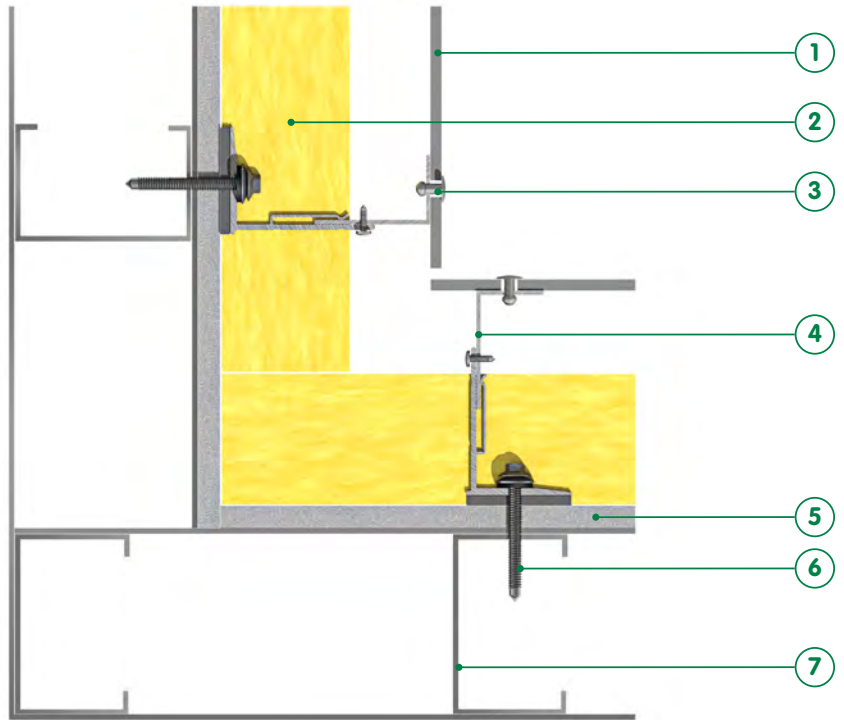

- 1 HardiePanel® cladding
- 2 Insulation
- 3 HardiePanel™ rivets for metal frame
- 4 Nvelope bracket system
- 5 Sheathing board
- 6 Anchor fixing
- 7 Steel frame sections

Nvelope NV1 Vertical Joint Detail

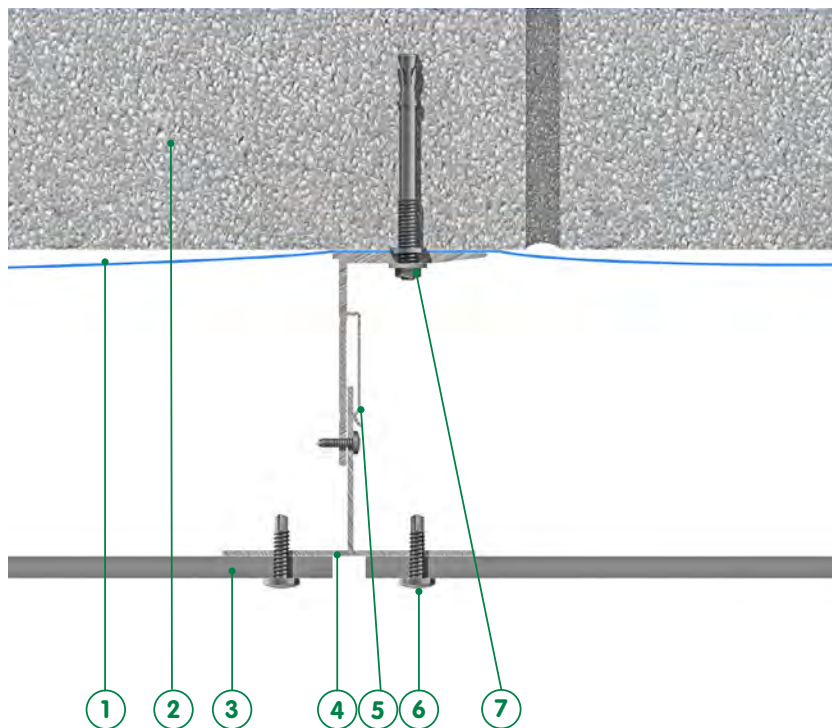

- 1 Breather membrane (if required)
- 2 Masonry
- 3 HardiePanel® cladding
- 4 EPDM gasket between board joints
- 5 Nvelope bracket system
- 6 HardiePanel™ screws for metal frames
- 7 Expanding anchor fixing

Nvelope NV1 Framing Detail with Rivet Fixing

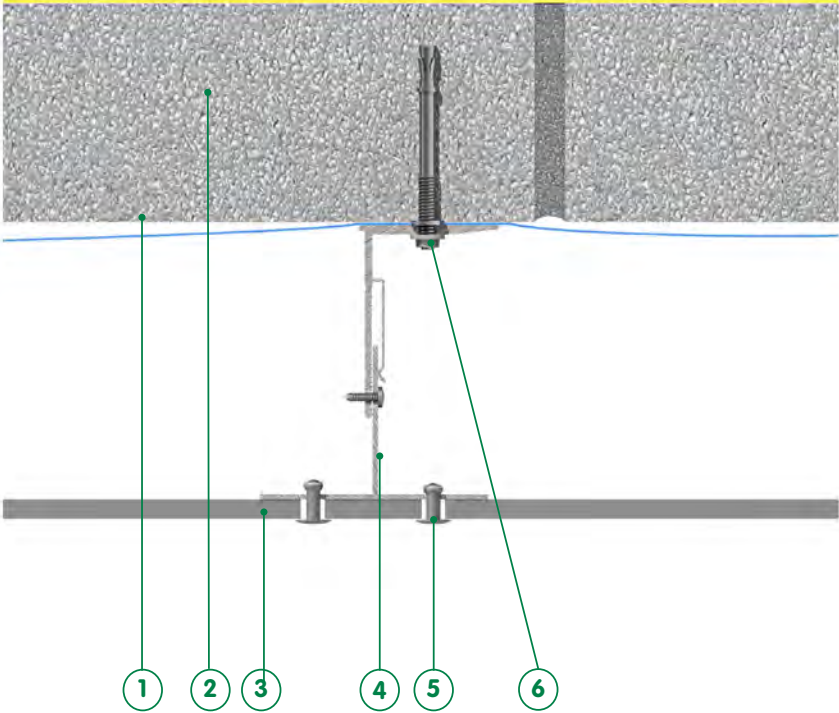

- 1 Breather Membrane (if required)
- 2 Masonry
- 3 HardiePanel® cladding
- 4 Nvelope bracket system
- 5 HardiePanel™ rivets for metal frame
- 6 Expanding anchor fixing

Nvelope NV1 Soffit and Fascia Detail

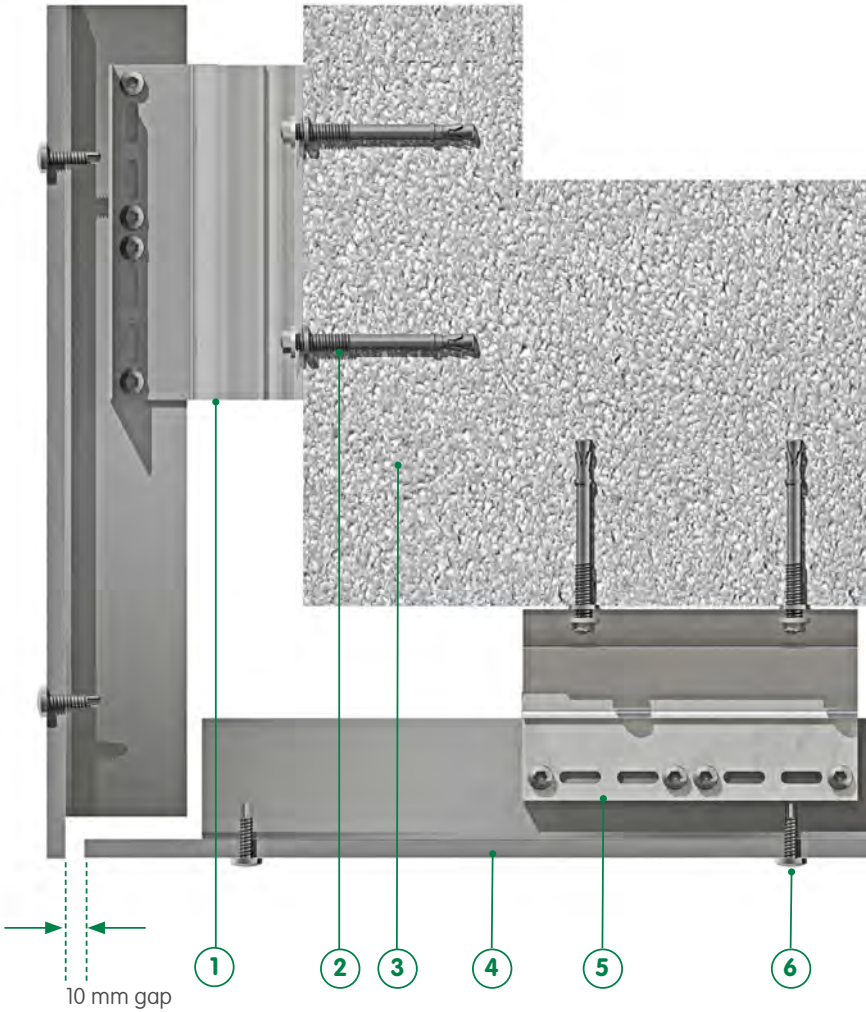

- 1 Nvelope bracket system
- 2 Expanding anchor fixing
- 3 Masonry
- 4 HardiePanel® cladding
- 5 Nvelope bracket system
- 6 HardiePanel™ screws for metal frames

Nvelope NV1 Vertical Joint Detail with Rivet Fixing

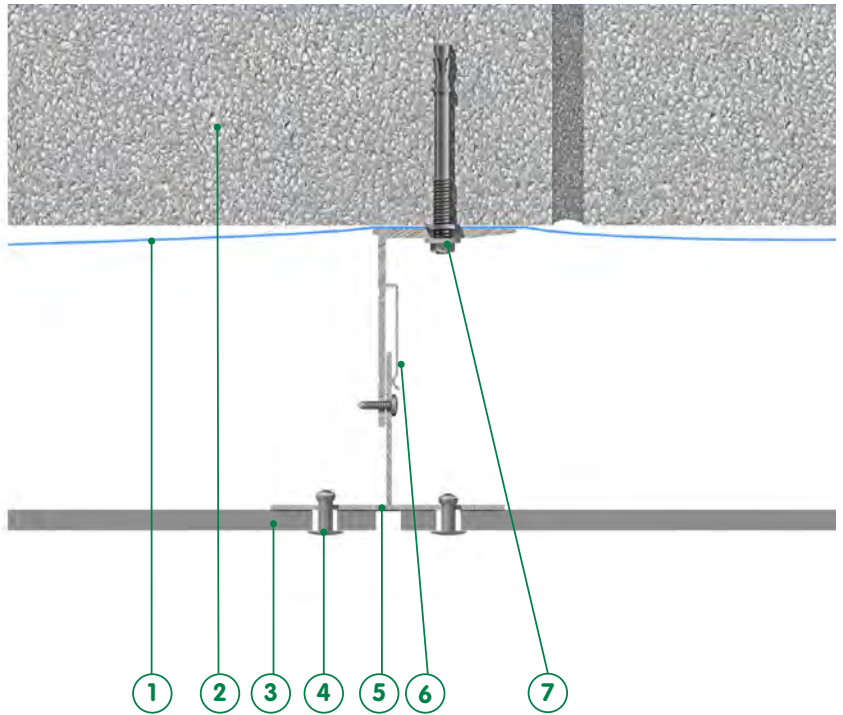

- 1 Breather membrane (if required)
- 2 Masonry
- 3 HardiePanel® cladding
- 4 HardiePanel™ rivets for metal frame
- 5 EPDM gasket between board joints
- 6 Nvelope bracket system
- 7 Expanding anchor fixing

Nvelope NV1 Soffit and Fascia Detail with Rivet Fixing

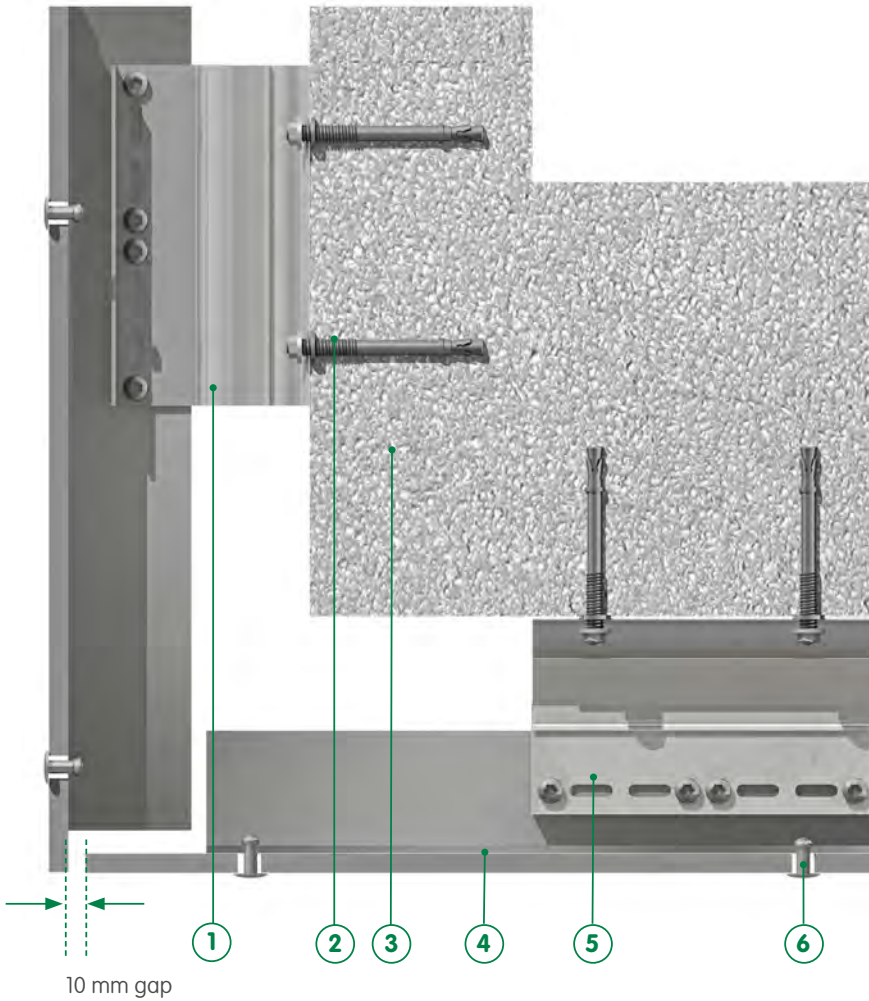

- 1 Nvelope bracket system
- 2 Expanding anchor fixing
- 3 Masonry
- 4 HardiePanel® cladding
- 5 Nvelope bracket system
- 6 HardiePanel™ rivets for metal frames

Nvelope NV1 Base Ventilation Detail with Rivet Fixing

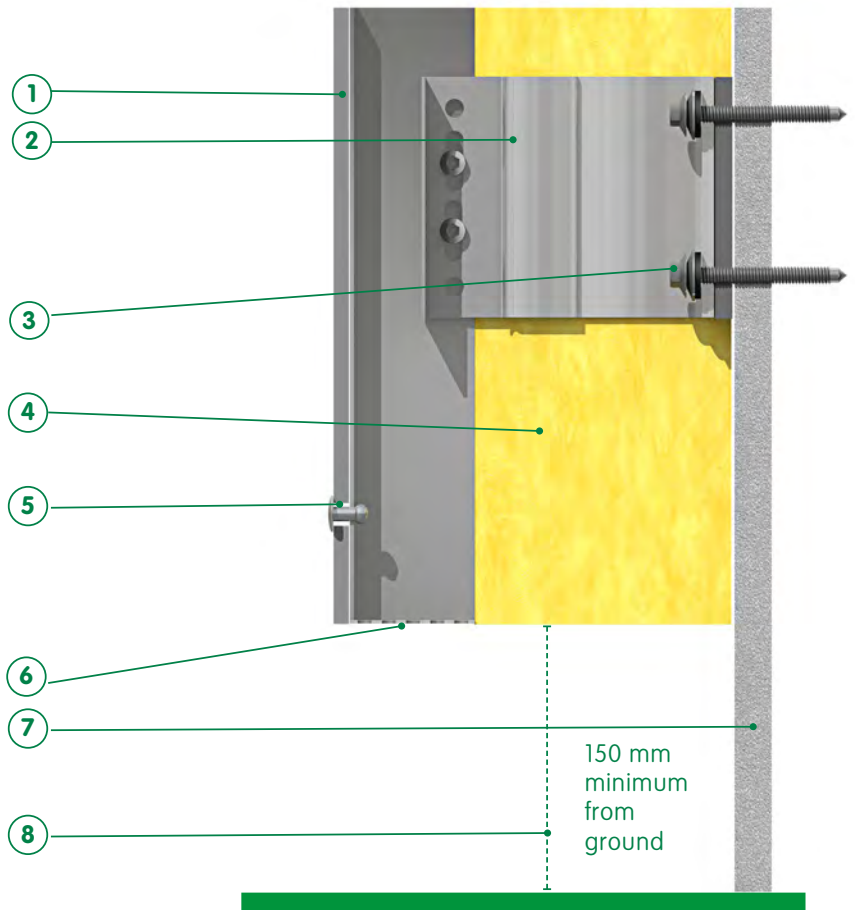

- 1 HardiePanel® cladding
- 2 Nvelope bracket system
- 3 Anchor fixing
- 4 Insulation
- 5 HardiePanel™ rivets for metal frames
- 6 Vent grill (supplied by others)
- 7 Sheathing board
- 8 150 mm minimum gap from ground

Nvelope NV1 Top Ventilation Detail with Rivet Fixing

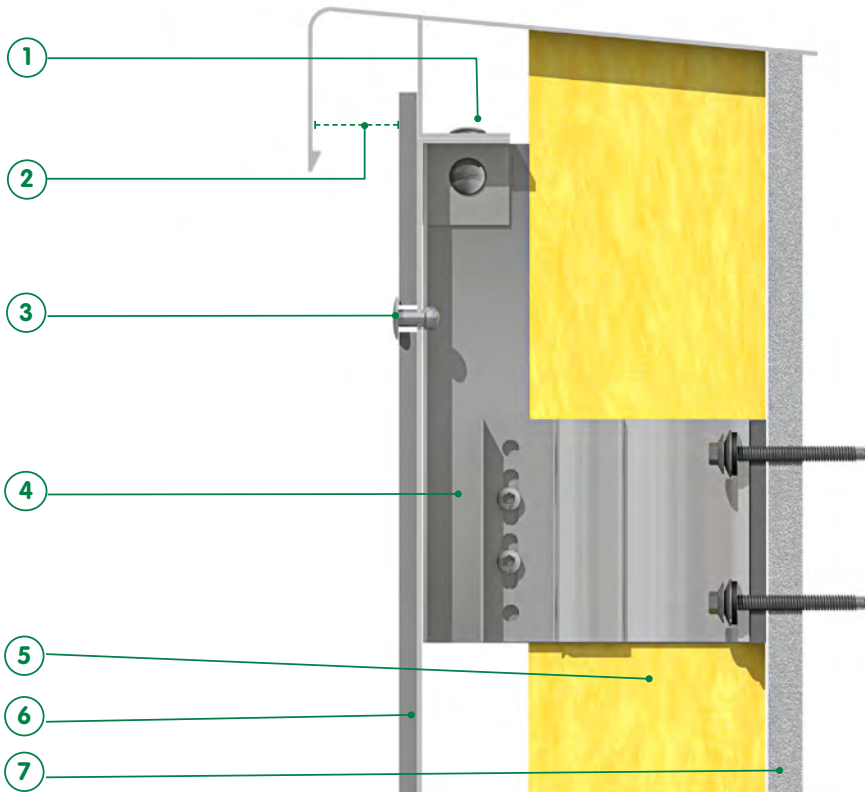

- 1 Support clip for flashing (flashing supplied by others)
- 2 Minimum 10 mm ventilation gap
- 3 HardiePanel™ rivets for metal frames
- 4 Nvelope bracket system
- 5 Insulation
- 6 HardiePanel® cladding
- 7 Sheathing board

Window Reveal with Rivet Fixing

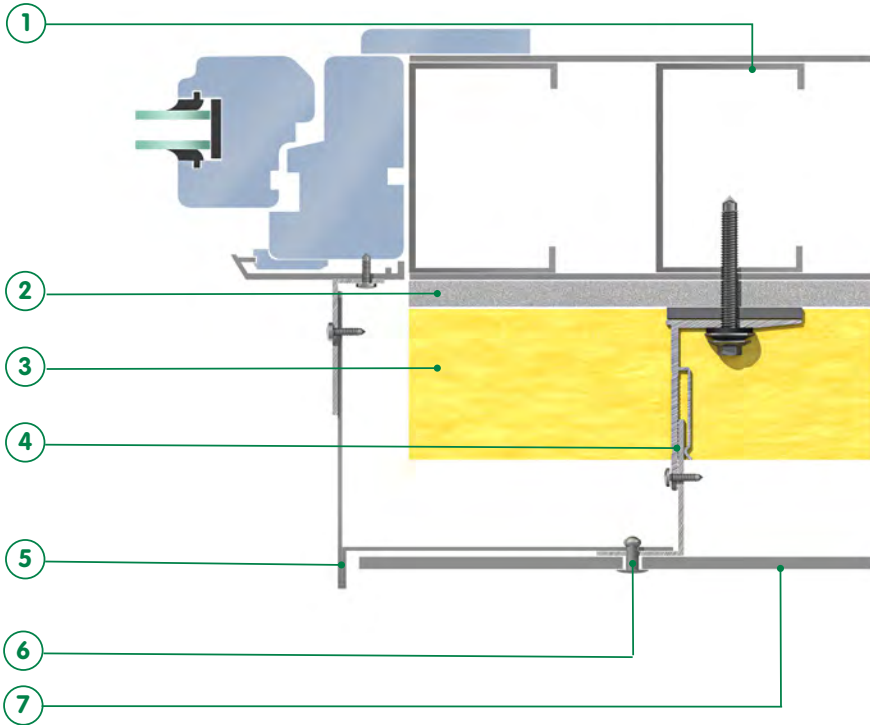

- 1 Steel frame section
- 2 Sheathing board
- 3 Insulation
- 4 Nvelope bracket system
- 5 Metal reveal (supplied by others)
- 6 HardiePanel™ rivets for metal frames
- 7 HardiePanel® cladding

Window Head with Rivet Fixing

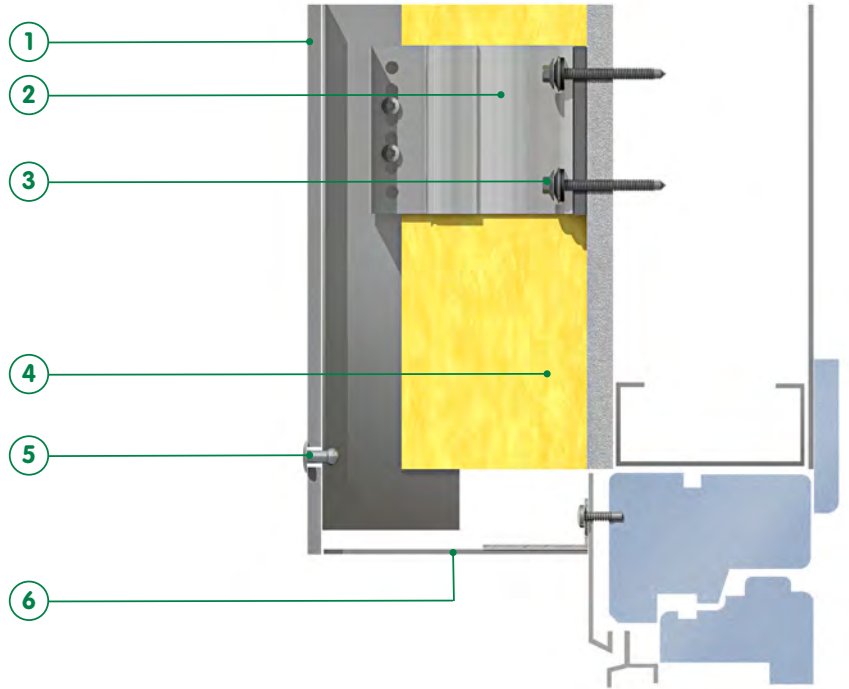

- 1 HardiePanel® cladding
- 2 Nvelope bracket system
- 3 Fixing anchor
- 4 Insulation
- 5 HardiePanel™ rivets for metal frames
- 6 Metal reveal (supplied by others)

Window Cil with Rivet Fixing

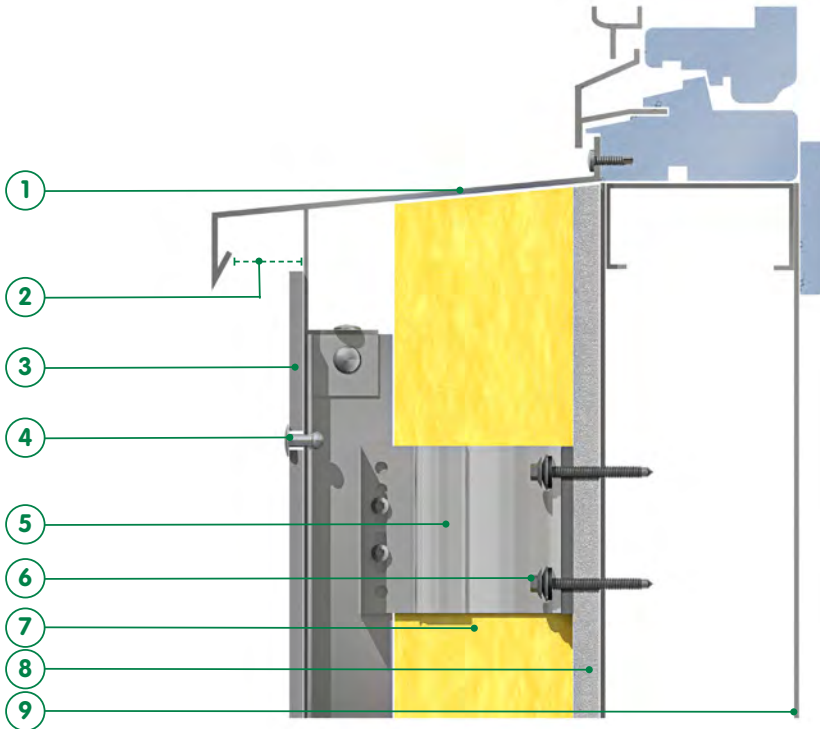

- 1 Powder coating metal flashing (supplied by others)
- 2 10 mm minimum ventilation gap
- 3 HardiePanel® cladding
- 4 HardiePanel™ rivets for metal frames
- 5 Nvelope bracket system
- 6 Fixing anchor
- 7 Insulation
- 8 Sheathing board
- 9 Steel frame section

Social housing project in Heathered Moss, Arctic White & Iron Grey smooth.



Installing HardiePanel® Cladding onto Timber Battens or Masonry

General Arrangement

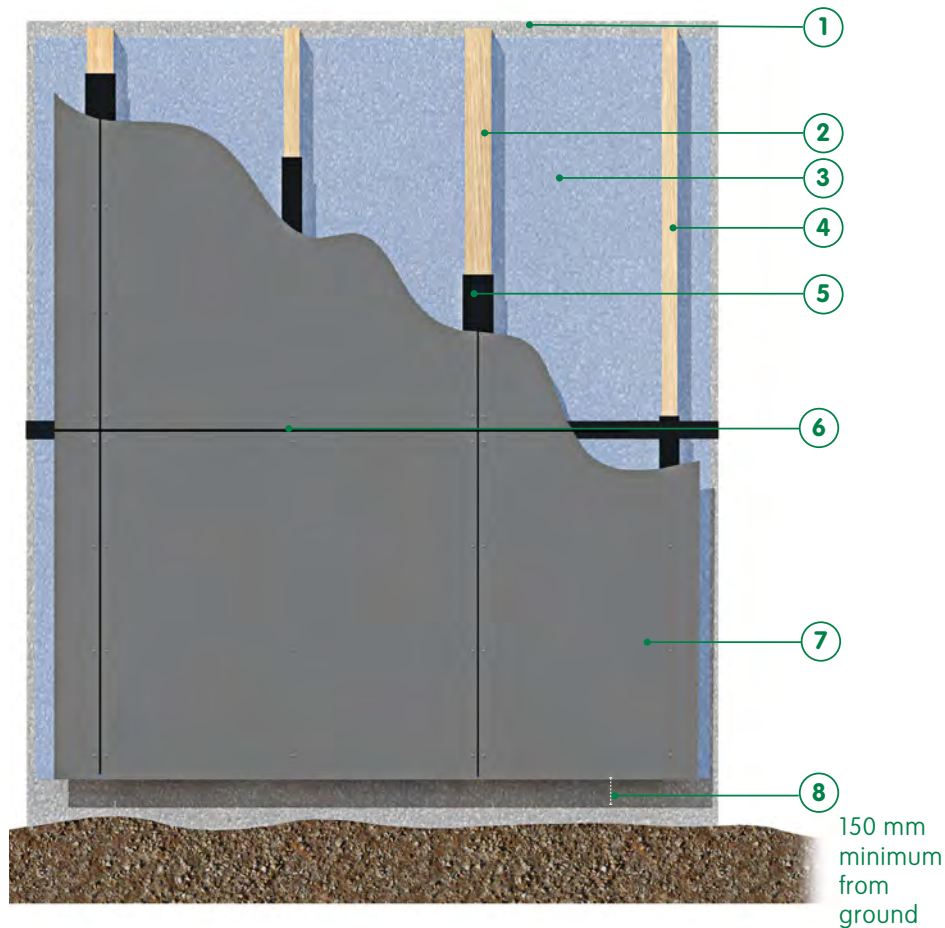

- 1 Masonry, Timber or Steel
- 2 Vertically installed timber battens 50 mm x 100 mm
- 3 Breather membrane - only required for low density/poor quality brick/blockwork
- 4 Vertically installed timber battens 50 mm x 50 mm
- 5 100 mm EPDM gasket
- 6 Z-Profile (if required)
- 7 HardiePanel® cladding
- 8 150 mm minimum from ground

Fixings installed

- (see pages 18-19)
- 50-100 mm from the top
 - 30 mm in - Metal
 - 20 mm in - Timber

Base Ventilation Detail

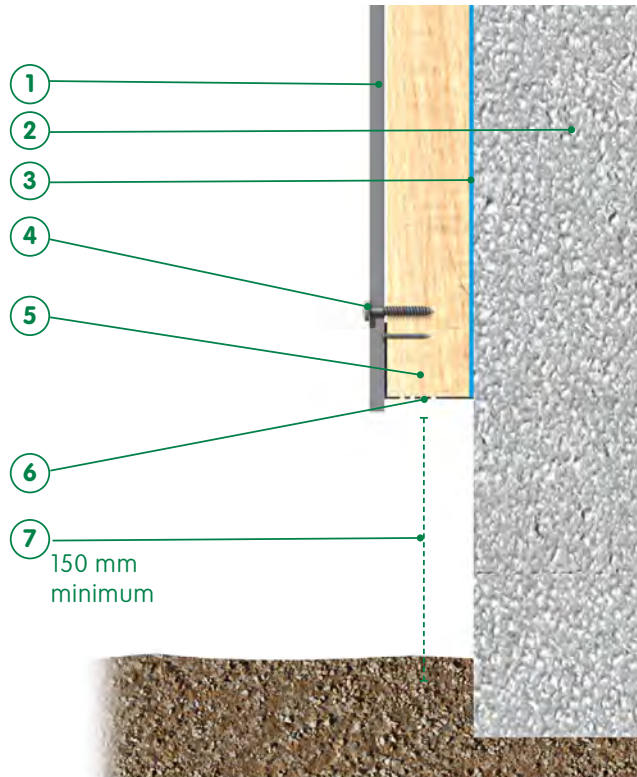

- 1 HardiePanel® cladding
- 2 Masonry wall
- 3 Breather membrane (if required)
- 4 HardiePanel™ screw for wood frames
- 5 50 x 50 mm Timber batten
- 6 HardiePanel™ ventilation profile
- 7 150 mm minimum gap

Top Ventilation Detail

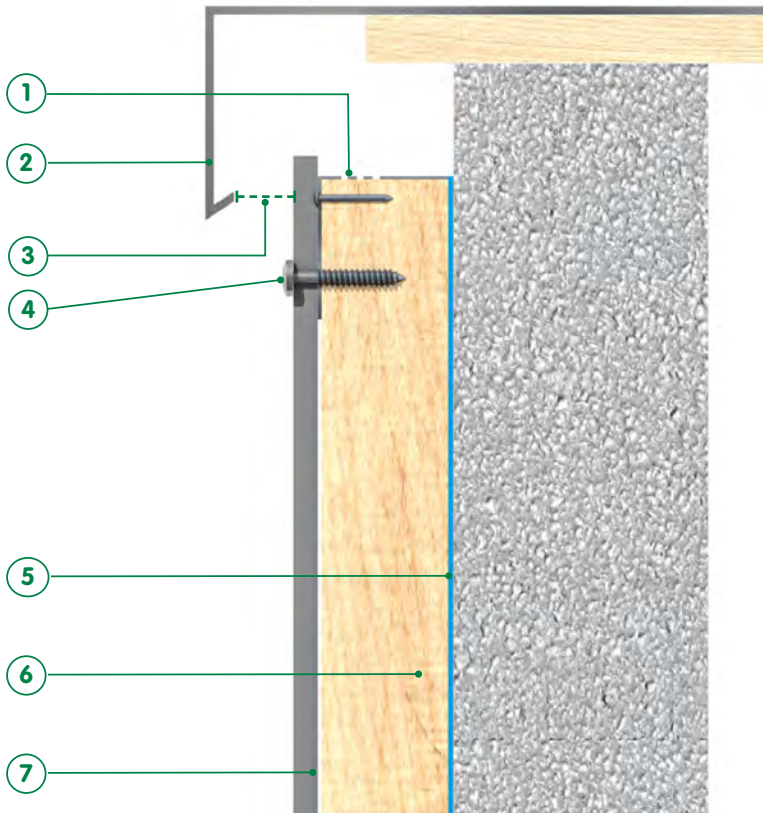

- 1 50 mm Top vent profile secured with nail
- 2 Metal flashing (supplied by others)
- 3 Minimum 10 mm ventilation gap
- 4 HardiePanel™ screw for wood frames
- 5 Breather membrane (if required)
- 6 50 mm x 50 mm Timber batten
- 7 HardiePanel® cladding

HardieTrim® External Corner Trim

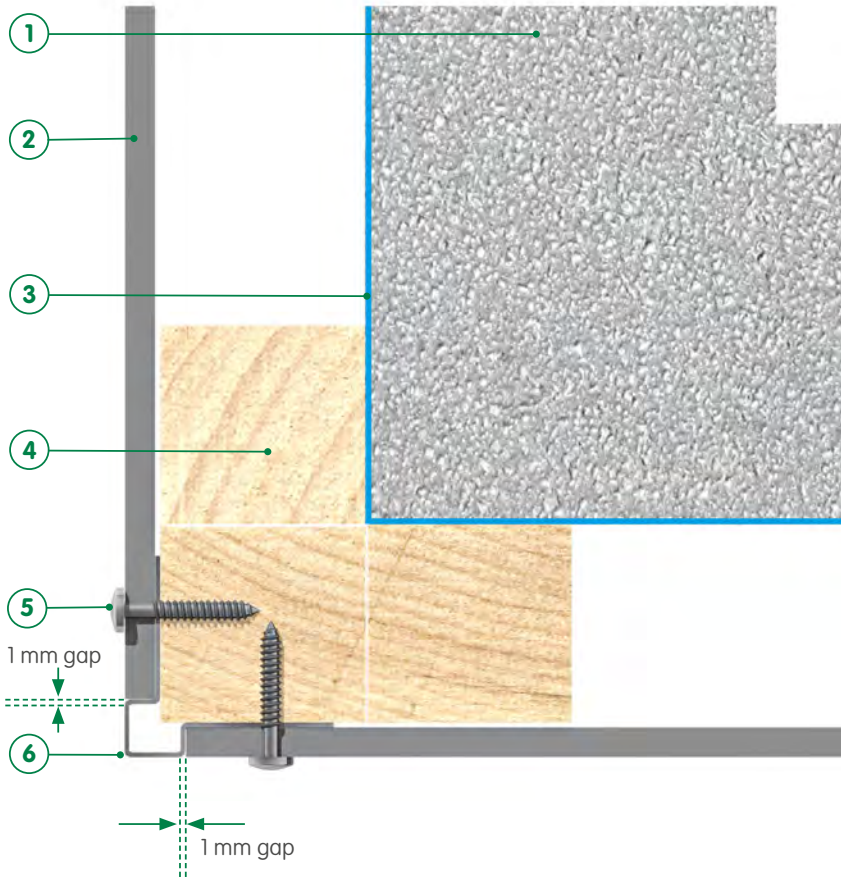

- 1 Masonry
- 2 HardiePanel® cladding
- 3 Breather membrane (if required)
- 4 50 mm x 50 mm Timber batten
- 5 HardiePanel™ screw for wood frames
- 6 MetalTrim™ profile

Internal Corner

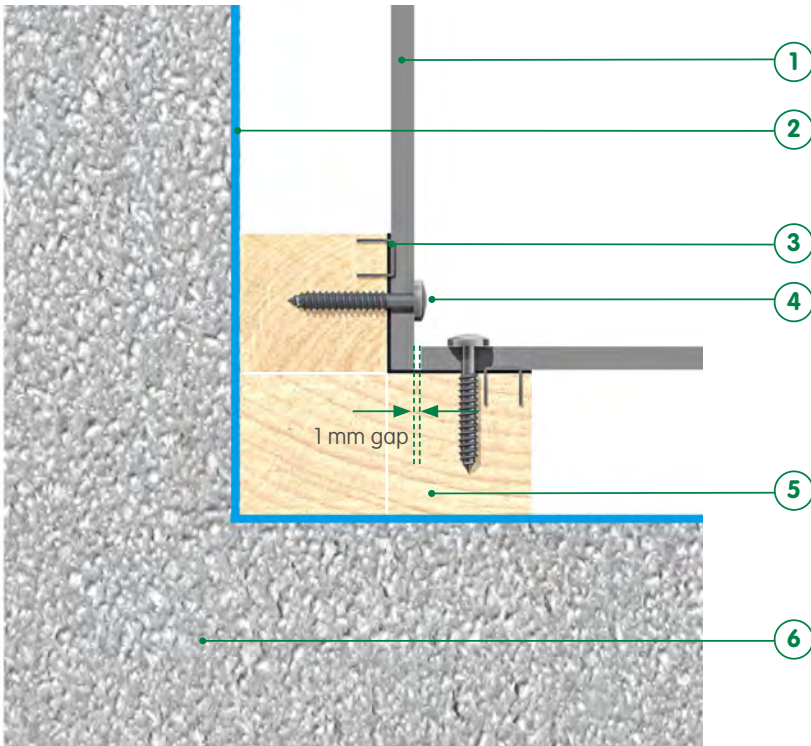

- 1 HardiePanel® cladding
- 2 Breather membrane (if required)
- 3 EPDM gasket stapled to batten
- 4 HardiePanel™ screw for wood frames
- 5 50 x 50 mm Timber batten
- 6 Masonry

Vertical Joint

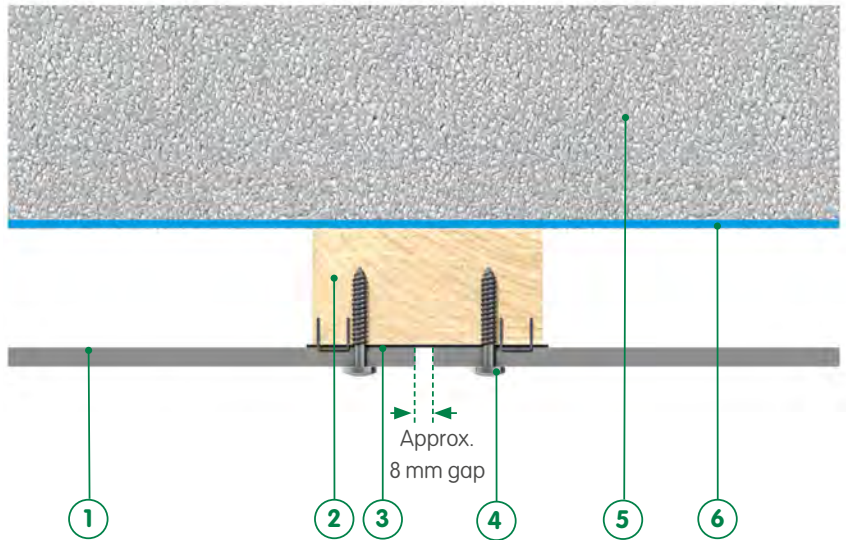

- 1 HardiePanel® cladding
- 2 50 x 100 mm Timber batten
- 3 EPDM gasket stapled to batten
- 4 HardiePanel™ screw for wood frames
- 5 Masonry
- 6 Breather membrane (if required)

Horizontal Joint Detail

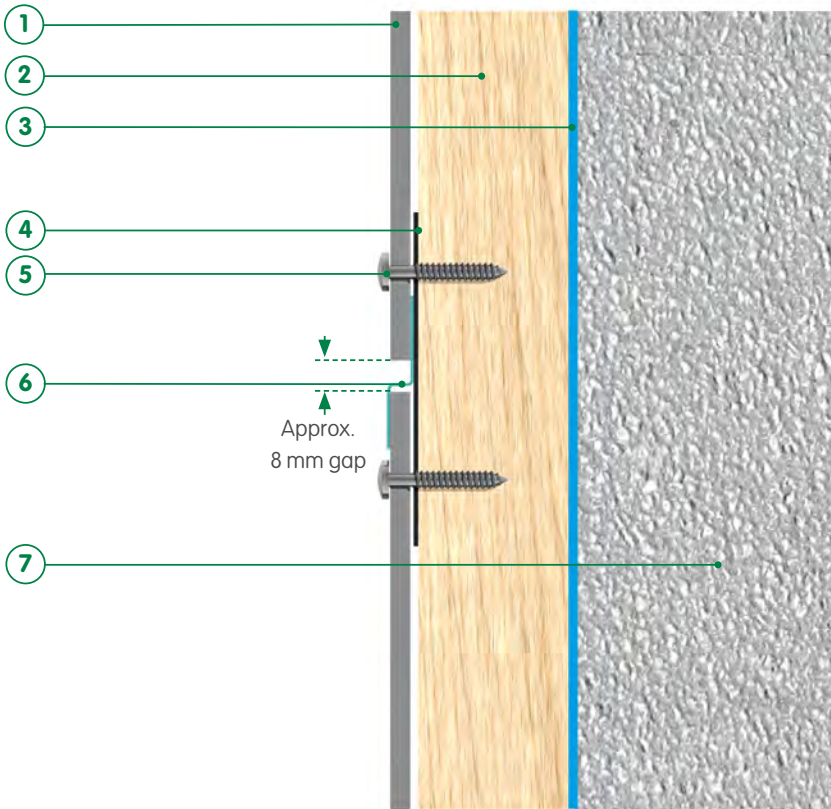

- 1 HardiePanel® cladding
- 2 50 x 50 mm Timber batten
- 3 Breather membrane (if required)
- 4 EPDM gasket stapled to batten (if desired)
- 5 HardiePanel™ screw for wood frames
- 6 Horizontal Z-profile*
- 7 Masonry

*only required for warranty purposes on projects above 600m altitude.

Expansion Gap Detail – Option 1

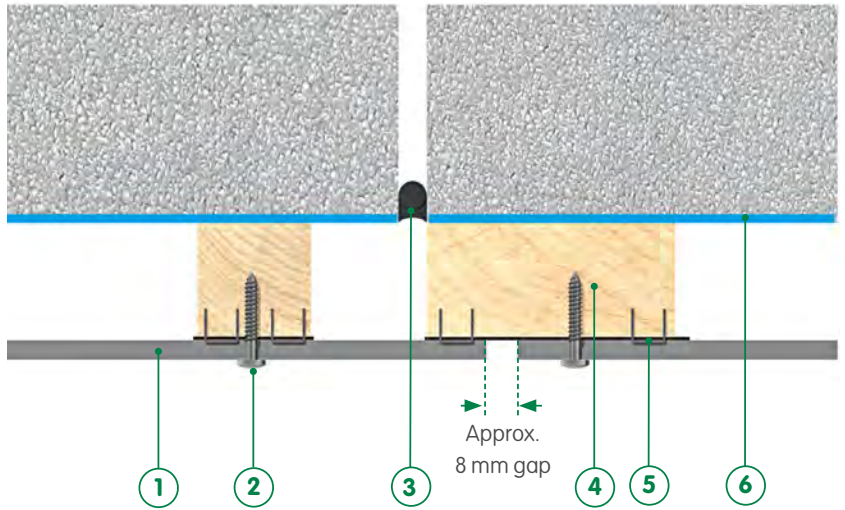

- 1 HardiePanel® cladding
- 2 HardiePanel™ screw for wood frames
- 3 Expansion gap
- 4 50 x 100 mm Timber batten
- 5 EPDM gasket stapled to batten
- 6 Breather membrane (if required)

Expansion Gap Detail – Option 2

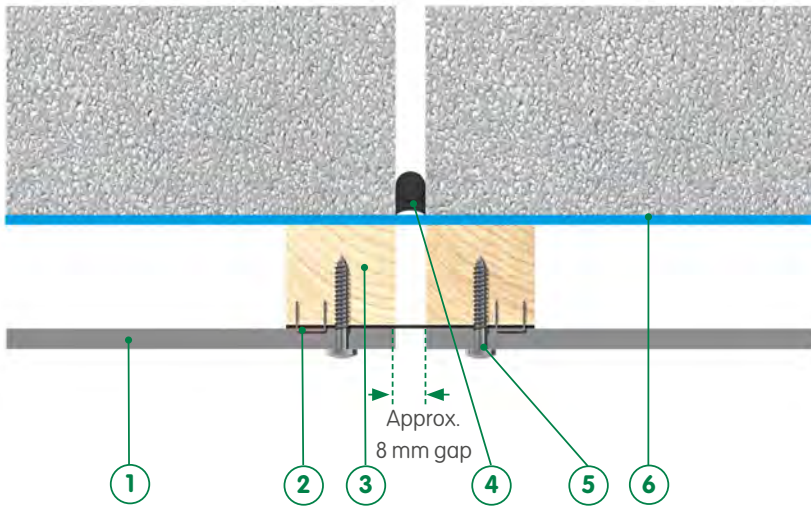

- 1 HardiePanel® cladding
- 2 EPDM gasket stapled to batten
- 3 50 mm x 50 mm Timber batten
- 4 Expansion gap
- 5 HardiePanel™ screw for wood frames
- 6 Breather membrane (if required)

Window Detail



Window Reveal

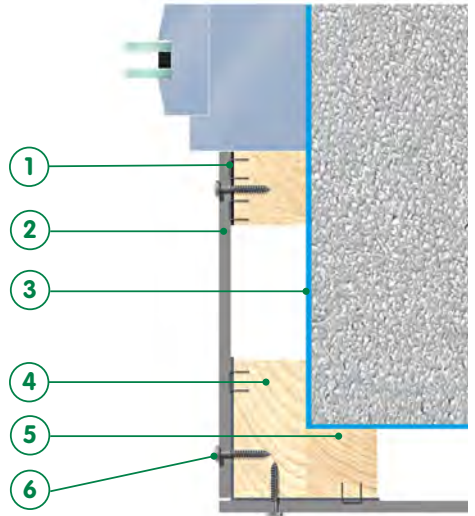

- 1 EPDM gasket stapled to batten
- 2 HardiePanel® cladding
- 3 Breather membrane (if required)
- 4 100 mm x 50 mm timber batten
- 5 50 mm x 50 mm timber batten
- 6 HardiePanel™ screw for wood frames

Window Head

- 1 HardiePanel® cladding
- 2 50 mm x 50 mm timber batten
- 3 HardiePanel™ screw for wood frames
- 4 50mm Top vent profile
- 5 10 mm minimum ventilation gap
- 6 HardiePanel® cladding

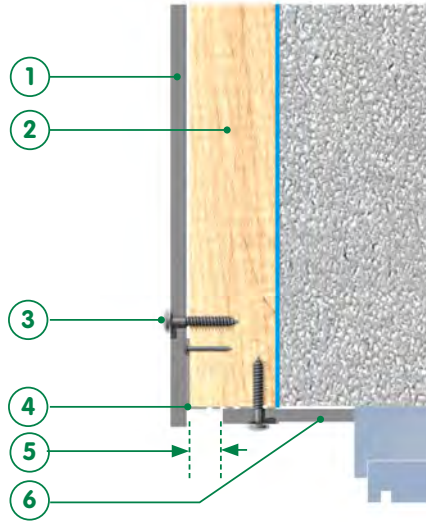

Window Cill

- 1 Metal flashing (supplied by others)
- 2 10 mm minimum ventilation gap
- 3 50 mm Top vent profile secured by nails
- 4 HardiePanel™ screw for wood frames
- 5 50 mm x 50 mm Timber batten
- 6 HardiePanel® cladding
- 7 Breather membrane (if required)

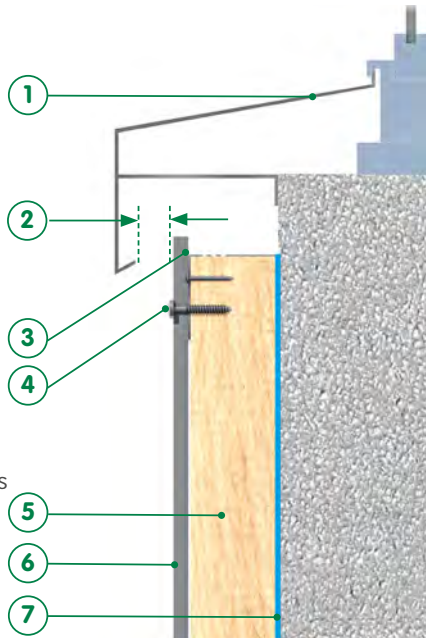

Maintenance

Annual Inspection

Environmental impacts may influence the visual appearance of the facade cladding. Therefore, an annual inspection of the ventilation gaps, joints and fixings is a good idea. Detection and repair of possible damages secure a prolonged lifetime for the facade cladding.

Impact from Nature

The weather and nearby green plants may affect the appearance of the facade cladding. Pollution, dust and leaves from trees, bushes and flowers can have an impact on the facade. Ensure plants are cut back from the facade and regularly clear gutters. HardiePanel® cladding is manufactured from weather resistant raw materials and will not be attacked by algae, rot and dry rot.

Cleaning

HardiePanel® cladding can be cleaned with cold or lukewarm water from a garden hose. If necessary add a mild household cleaning agent not containing solvents. Always start from the top with well-defined areas. Rinse with clean water.

Before cleaning full scale, it is recommended to test the chosen cleaning method on a smaller area to make sure it is fit for purpose.

Moss & Algae

Moss and algae growth can be removed with common agents available on the market. Examples are hypochlorite that has no long term effect or benzalconiumchloride 2.5% active that has a long term effect preventing new growth. After wetting the facade with clean water, the agent is applied according to the supplier's instructions. Do not leave the agent to dry completely. Rinse with lots of clean water.

High Pressure Cleaning

Do not use high pressure cleaning systems as they may damage the ColourPlus™ coating.

Health & Safety

Avoid Breathing Dust

James Hardie products contain crystalline silica. This mineral is found everywhere in the world (often in the form of sand) and therefore is commonly used in many construction products (for example brick, concrete, glass wool and abrasives). The mineral itself is inert, but certain building practices such as drilling, high speed cutting and abrading can release fine particulate dust which may constitute a health hazard.

Excessive or protracted inhalation of fine particle silica dust can lead to a lung disease called Silicosis. There is also some evidence that it may increase the risk of lung cancer if inhaled for prolonged periods. Smoking may also exacerbate this risk. Like smoking, the risk from fine particle silica dust is time and concentration dependent.

Control

To suppress or to reduce excessive inhalation of fine particle silica dust the following steps should be taken to protect operatives who work with products containing silica dust:

During fabrication operate outdoors or in well ventilated space in a separate area if available or away and down-wind from other operatives;

Use controlled dust cutting tools, such as the HardieBlade™ saw blade fitted to a low dust circular saw connected to a dust extraction HEPA filter vacuum cleaner (see James Hardie tools);

When cutting, drilling or abrading always wear a FFP2/3 dust control or full face mask adjusted and fitted in conformity with regulatory recommendations and affixed with CE marking and/or fully certified to the relevant EN standards if applicable;

Keep the working environment clean and remove debris as soon as possible; and

At the end of the operation remove dust from clothes, tools and work area with a HEPA filter vacuum cleaner or damp with water to suppress the dust before sweeping.

Remember, James Hardie products are no more dangerous than many other building materials containing crystalline silica sand. We hope through this information to engage in effective education of the construction industry and build upon the requirements of national health and safety regulations.

For more information, see our installation instructions and MSDS available on www.jameshardie.co.uk or call James Hardie.

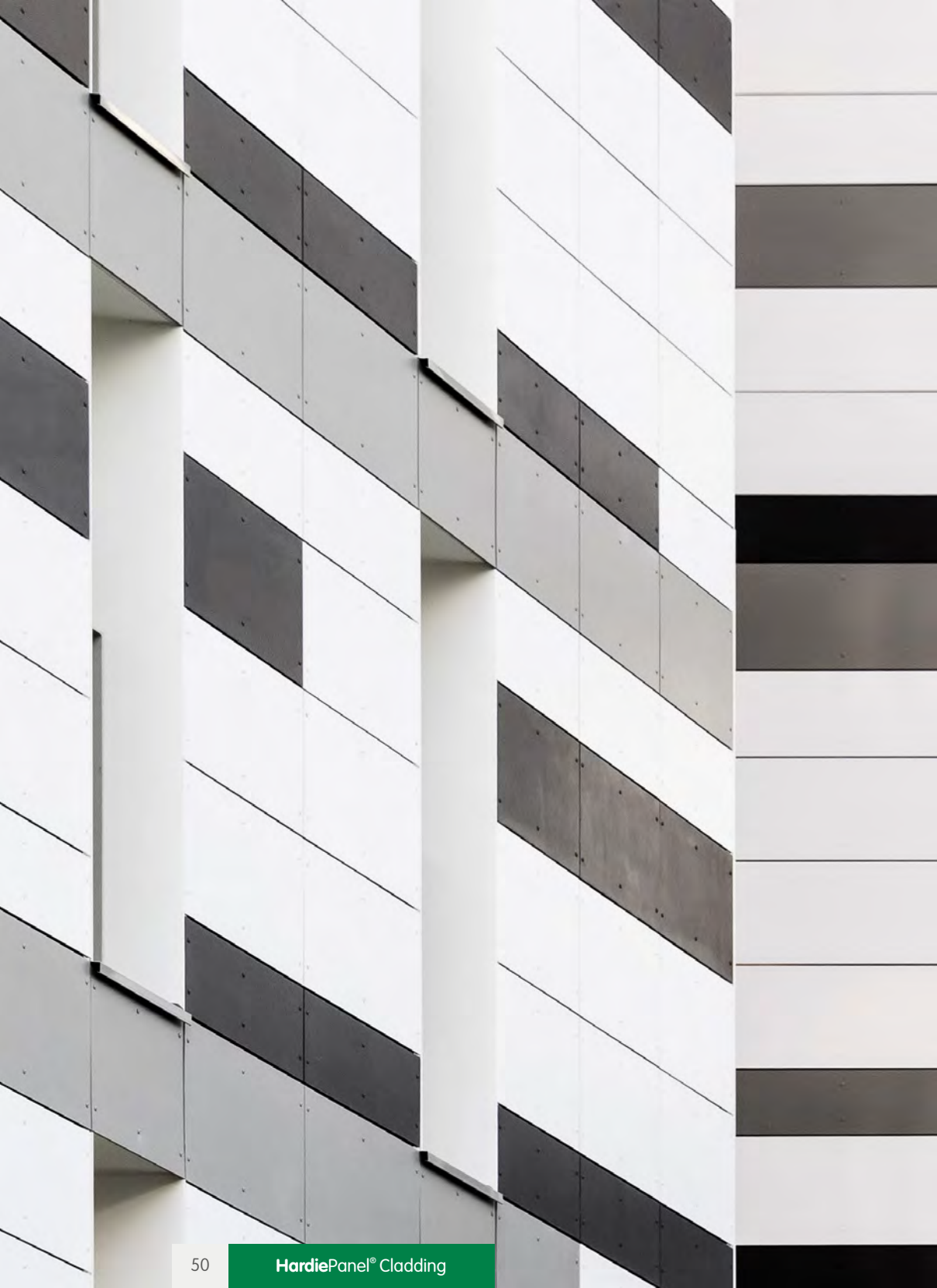

General Information

Service

If you have any questions regarding HardiePanel® cladding, our staff are ready to assist you with advice and guidance. Please, ensure that you have the latest version of this publication, by checking that the publication date corresponds with the downloadable version from our website www.jameshardie.co.uk. In case of doubt, please contact your local James Hardie® representative.

Warranty

Warranty conditions can be commissioned at James Hardie Europe BV.

Additional Information

Additional information including CAD details and test reports are available at www.jameshardie.co.uk

Specific Installation

For any installation which is not covered in this manual, please contact our technical service at the number below.

James Hardie Building Products Ltd
One Fleet Place, London EC4M 7WS

T: 0800 068 3103

E: info@jameshardie.co.uk

www.jameshardie.co.uk

Disclaimer

The information contained in this publication and otherwise supplied to users of HardiePanel® products is based on James Hardie's general experience, best knowledge and belief. However because of factors that fall beyond James Hardie's knowledge and control, which can affect the use of the products, no warranty is given or implied with respect to such information. James Hardie's policy is one of continuous improvement. James Hardie therefore reserves the right to alter specifications at any time and without notice.

For renovation construction see drawings on www.jameshardie.co.uk.

info@jameshardie.co.uk
www.jameshardie.co.uk

© 2019 James Hardie Europe GmbH. TM and [®] denote registered and unregistered trademarks of James Hardie Technology Ltd and James Hardie Europe GmbH.

A James Hardie 10 year warranty applies to all our fibre cement products. Please see www.jameshardie.co.uk/warranty for terms and conditions.